

NOTE

1. RATING : DC 12V 50mA
2. CONTACT RESISTANCE : 100mΩMAX
3. GENERAL TOLERANCE : +/- 0.3 mm
4. MANUFACTURING SPECIFICATION
WOULD BE ACCORDANCE WITH WT0158
5. PART NO.(P/N.):

TS502VMG - * * * R - R

5.2 x 5.2 mm
VERTICAL

DIMENSION "H"
015=1.5mm
020=2.0mm
025=2.5mm

OPERATING FORCE
A=100gf
B=160gf
C=260gf

STEM
□= STANDARD

PACKING
R=REEL

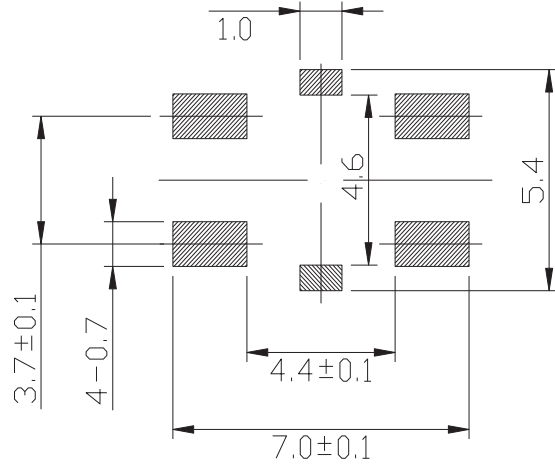

P. C. B LAND DIMENSION

TS502VMG-025 * R-R	2.5 mm
TS502VMG-020 * R-R	2.0 mm
TS502VMG-015 * R-R	1.5 mm
MODEL NO.	"H"

RevNo	Revision note	Date	Signature

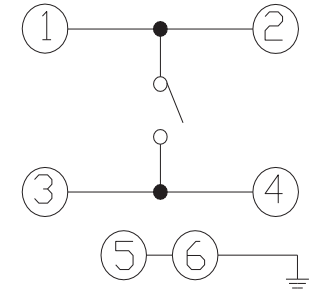
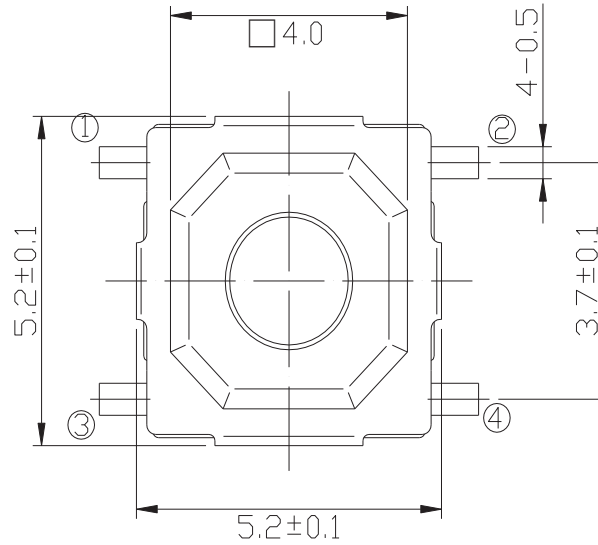

CIRCUIT DIAGRAM

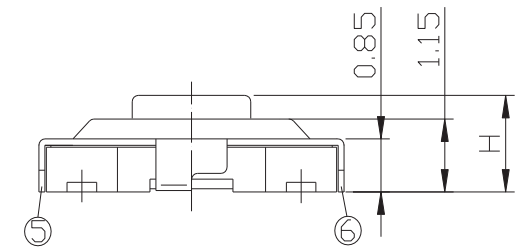
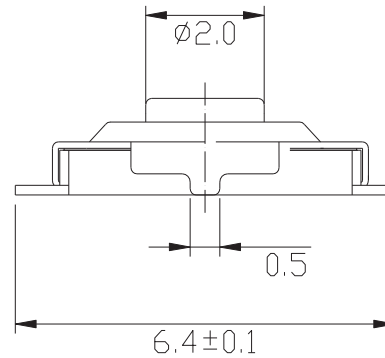

Designed by L.Y.D		CHAMPWAY 冠泰電子有限公司 CHAMPWAY ELECTRONICS CO., LTD.		
Checked by		Unit mm	Scale 1/1	Date 2011.10.14
Approved by	Item Tactile Switch	Tool A-Cad	Sheet 1/1	Rev. 0
Model 5.2X5.2 SMD	Drawing name TS502VMG- * * R-R			